

**Adam Stawiarski\*, Stanisław Miarka, Marek Barski, Paweł Romanowicz**

*Cracow University of Technology, Institute of Machine Design, ul. Warszawska 24, 31-155 Krakow, Poland*

*\*Corresponding author. E-mail: asta@mech.pk.edu.pl*

*Received (Otrzymano) 20.01.2016*

## FATIGUE DAMAGE DETECTION IN COMPOSITE PLATE WITH A CIRCULAR HOLE BY ELASTIC WAVE PROPAGATION METHOD

In this study, the elastic wave propagation phenomenon was used to detect the initiation of fatigue damage in a composite plate with a circular hole. The Structural Health Monitoring (SHM) system based on the active pitch-catch measurement technique was proposed. Two configurations of measuring points location were taken into account. The signals from the intact structure were compared with the dynamic response from a structure having a relatively small, interlaminar defect. The influence of the measuring points (actuators and sensors) location on the effectiveness of the damage detection method was performed to obtain an efficient system which can detect the initiation of fatigue damage in a composite plate with a circular hole.

**Keywords:** wave propagation, fatigue damage, SHM, damage detection

## WYKRYWANIE USZKODZEŃ ZMĘCZENIOWYCH W KOMPOZYTOWEJ PŁYCCIE Z OTWOREM METODĄ PROPAGACJI FAL SPRĘŻYSTYCH

W pracy wykorzystano metodę propagacji fal sprężystych do wykrywania inicjacji uszkodzeń zmęczeniowych w kompozytowej płycie z otworem. Zaproponowano system SHM (Structural Health Monitoring) oparty na aktywnej, transmisyjno-odbiorczej technice pomiarowej. Uwzględniono dwie konfiguracje rozmieszczenia punktów pomiarowych. Sygnały pochodzące ze struktury wzorcowej porównano z dynamiczną odpowiedzią płyty zawierającej stosunkowo niewielki, międzywarstwowy defekt. Określono wpływ lokalizacji punktów pomiarowych (aktywatorów i sensorów) na skuteczność metody detekcji w celu uzyskania efektywnego systemu umożliwiającego wykrycie inicjacji uszkodzenia zmęczeniowego w kompozytowej płycie z otworem.

**Słowa kluczowe:** propagacja fal sprężystych, uszkodzenie zmęczeniowe, SHM, detekcja uszkodzeń

## INTRODUCTION

The necessity to permanently monitor the state of structures has been observed in recent years, especially in composite materials. The number of non-destructive inspection techniques is growing and depends on the engineering application. The great number of engineering materials and the difficulties associated with accurately estimating fatigue strength have led to the development of Structural Health Monitoring (SHM) systems. The majority of the present SHM systems based on the elastic wave propagation phenomenon describe the changes in the temporal signal features in the time domain with respect to the baseline signals [1, 2]. Different techniques of wave propagation measurement and data analysis have been developed and verified in real structures [3-5]. Most of them concern plate-like structures with an embedded piezoelectric sensor network [6, 7]. The problem of fatigue cracks initiating from a hole in isotropic materials is well known and commonly observed especially in the air-

craft industry [8]. Different non-destructive testing methods have been developed for the early detection of such defects [9]. The analysis of elastic wave propagation in composite structures with a hole is complicated because of the reflections from the boundary of the structure [10]. Some researchers considered scattering a guided wave by a crack near the hole [11, 12]. The methodology of monitoring and observing fatigue crack growth also has been presented in literature [13-15]. However, most of the studies deal with isotropic materials. The anisotropic properties of composite structures, and the great number of failure forms introduce additional complications to damage detection systems [16-18]. The problem of fatigue degradation of aerospace composites and non-destructive techniques like monitoring strain or operational loads were presented by Giurgiutiu [19]. The method of detecting and estimating composite fatigue damage in the form of matrix microcracks and delamination by observing guided

wave propagation was proposed by Larrosa et al. [20]. The application of piezoelectric active wafer sensors (PAWS) in monitoring and detecting damage initiation in a composite wind turbine rotor blade is shown in [21].

In this paper, the elastic wave propagation method was utilised to detect an interlaminar fatigue defect near a circular hole with the use of a small number of measuring points. The influence of the actuator and sensors location on the efficiency of the proposed method has also been considered.

### FORMULATION OF FINITE ELEMENT MODEL

A composite multilayered plate with a circular hole in the middle is considered. The thickness of the plate is equal to 2 mm. The dimensions of the interlaminar defect on the edge of the hole are presented in Figure 1. The finite element ANSYS package has been used to evaluate the dynamic behavior of the composite structure. The 3D solid 186 finite element type with 20 nodes was used in modelling the structure. An appropriate finite element model of elastic wave propagation phenomenon has to satisfy several requirements. The mesh density features 8 nodes per wavelength. The time step for dynamic analysis is less than the ratio of the minimum distance of any two adjoining nodes to the maximum wave velocity. The laminate should be divided into sub-laminates in thickness to characterize individual laminae especially when we consider interlaminar delamination in a composite structure.

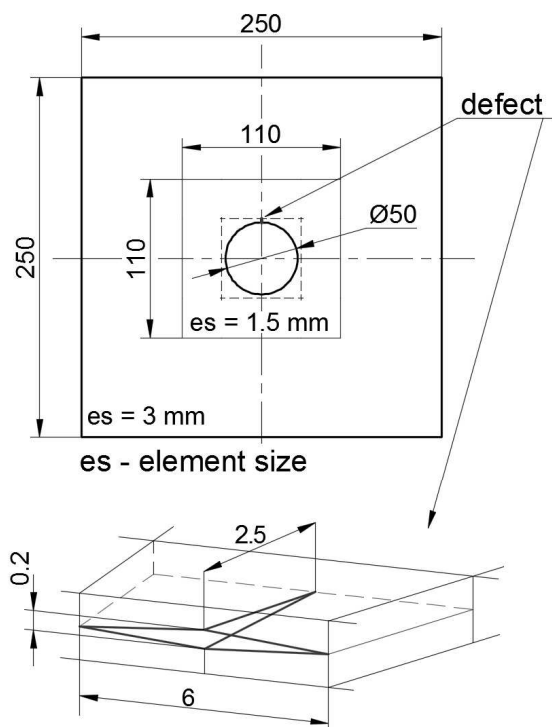

Fig. 1. Geometry of composite plate with circular hole and interlaminar fatigue defect

Rys. 1. Geometria kompozytowej płyty z otworem i uszkodzeniem zmęczeniowym

In this study, the model has been divided into two areas. The first area around the hole has an approximate element size equalling 1.5 mm. The rest of the plate, where propagation of the elastic wave is not so important from the damage detection point of view, features a 3 mm element size. The mentioned features of a finite element model and the application of a higher order element type allow one to evaluate accurate results of guided wave propagation in a composite material.

The composite plate was made of glass woven roving having the following properties  $E_1 = E_2 = 13.4$  GPa,  $G_{12} = 4.1$  GPa,  $\nu_{12} = 0.26$ ,  $\rho = 1700$  kg/m<sup>3</sup> where  $E_1$  and  $E_2$  are the longitudinal and transverse Young's moduli,  $G_{12}$  is the inplane shear modulus,  $\nu_{12}$  - inplane Poisson's ratio and  $\rho$  - density. The longitudinal fibers direction is parallel to the bottom edge of the plate (Fig. 1). A typical SHM system based on wave propagation generated by piezoelectric (PZT) elements has in the hardware part a multichannel elastic wave generation and acquisition system. In the present numerical FEM investigations, the hardware part has been replaced by a time-dependent concentrated force (normal to the surface) applied to the selected node in a form compatible with the experiment one. Therefore, it can be assumed that only antisymmetric mode  $A_0$  of the Lamb wave is excited. The fifth cycle of the Hanning windowed tone burst excitation signal was considered with the frequency  $f_0 = 100$  kHz. The form of the excitation signal is defined by Eq. (1).

$$F(t) = \begin{cases} \frac{1}{2} F_0 \left[ 1 - \cos\left(\frac{2\pi f_0 t}{n_0}\right) \right] \sin(2\pi f_0 t), & t \leq \frac{n_0}{f_0} \\ 0, & t > \frac{n_0}{f_0} \end{cases} \quad (1)$$

where  $F_0 = 1000$  N defines the amplitude of the applied force and  $n_0$  is the number of wave packages. The form of the excitation signal is shown in Figure 2.

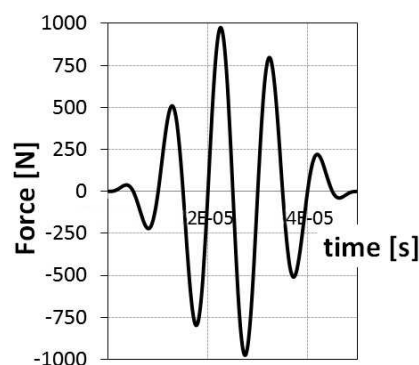

Fig. 2. Form of excitation signal

Rys. 2. Forma sygnału wymuszenia

It is worth pointing out that the main objective of wave propagation observation is to compare the signal detected by sensors in structures with and without damage. Thus, only the first signal generated by the actuator

is considered (reflections from the boundary are not taken into account). The mutual position of the actuator and sensors in the multipoint measuring system defines the analysed area and determines the time of the analysis.

## CONFIGURATION OF THE SHM SYSTEM

The efficiency of the damage detection system depends on the number and location of the actuator and sensors in the analysed area. In this paper, one actuator (act) generates the elastic wave which propagates through the structure and three sensors (s1, s2, s3) detect the dynamic response of the plate. Two configurations of measuring point locations have been proposed to verify the effectiveness of early detection of a small interlaminar defect (Fig. 3).

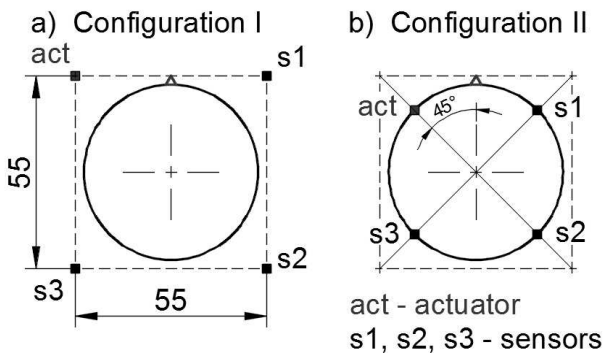

Fig. 3. Two proposed configurations of actuator and sensor location  
Rys. 3. Dwie konfiguracje rozmieszczenia aktywatora i sensorów

The first configuration (Fig. 3a) contains measuring points placed near the hole edge. The wave propagation path, understood as the shortest track connecting the actuator and sensor (s1), lay close to the defected area. The second configuration (Fig. 3b) contains the actuator and sensors placed directly on the hole edge. The elastic wave propagates along the hole edge passing through the damaged zone. The second configuration allow one to analyse the wave propagation without reflections from the boundary.

## WAVE PROPAGATION RESULTS

The basic assumption of the SHM system based on the wave propagation method is the comparison of a potentially defected structure with an intact one to observe the change in the dynamic response. In this paper, the pitch-catch measurement technique has been applied where the disturbance caused by the defect is analyzed. The reflections from the boundary and from the interlaminar defect are not taken into account. The view of the elastic wave fronts propagating through the structure in the composite plate demonstrates the importance of actuator location in dynamic response analysis (Fig. 4).

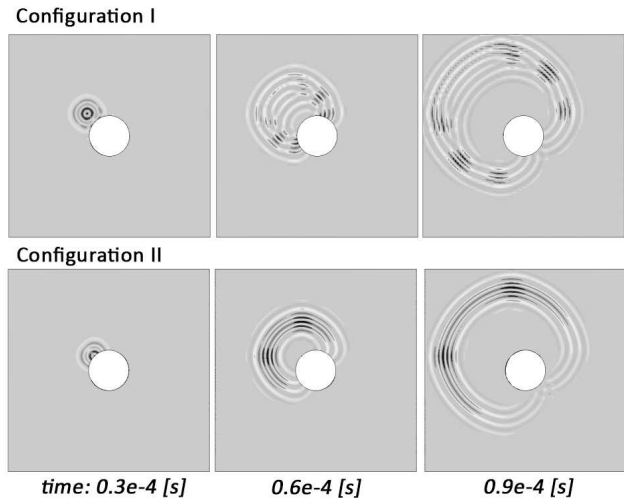

Fig. 4. Comparison of wave propagation for two configurations of actuator location

Rys. 4. Porównanie propagacji fali sprężystej dla dwóch konfiguracji rozmieszczenia aktywatora

In the first case of configuration, where the actuator is placed at some distance from the hole edge, the reflections from the boundary affect the wave propagation and complicate the interpretation of appropriate sensor placement. To avoid such difficulties, a second configuration has been proposed where reflections from the boundary have been avoided. The direct comparison of wave propagation described as a normalized lateral displacement in the intact and defected structure allow one to determine the state of the structure. The results for the first configuration of sensors placement (Fig. 5) indicate that early detection of the interlaminar defect cannot be effective when the measuring points are distant from the hole. The signals from the structure with a small interlaminar defect are identical to those from the intact plate. The assumed small size of the defect is undetectable if the wave propagation path does not pass through the defected area. The reflections from the hole edge additionally complicate the elastic wave behaviour.

The second configuration of measuring points placement demonstrates the effectiveness of the damage detection process (Fig. 6).

The elastic wave excitation on the edge of the considered hole allows monitoring of the change in the signal caused by the defect. The significant difference between the signals from the intact and defected structure was observed by sensors s2 and s3 for which the wave propagation path passed through the defected zone. The relatively small interlaminar defect causes a change in the amplitude of the signals. The phase shift is negligible. A noticeable decrease in the amplitude indicates the fact that an interlaminar defect impairs the elastic wave but does not change the characteristic of the wave. This feature can be used by an automatic damage detection algorithm which processes the measured data into information about potential damage detection.

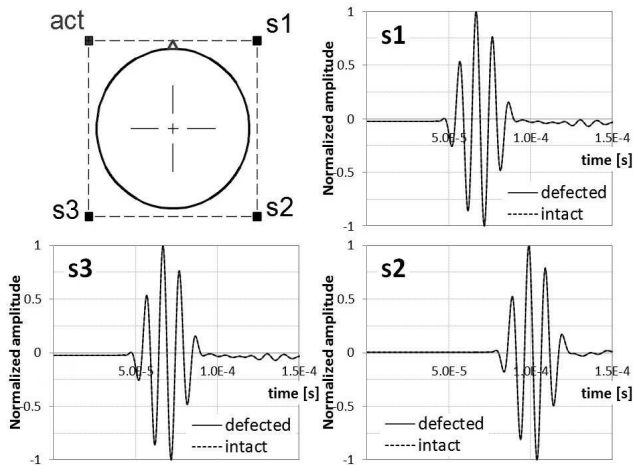

Fig. 5. Comparison of wave propagation for first configuration of sensor location

Rys. 5. Porównanie propagacji fali sprężystej dla pierwszej konfiguracji rozmieszczenia sensorów

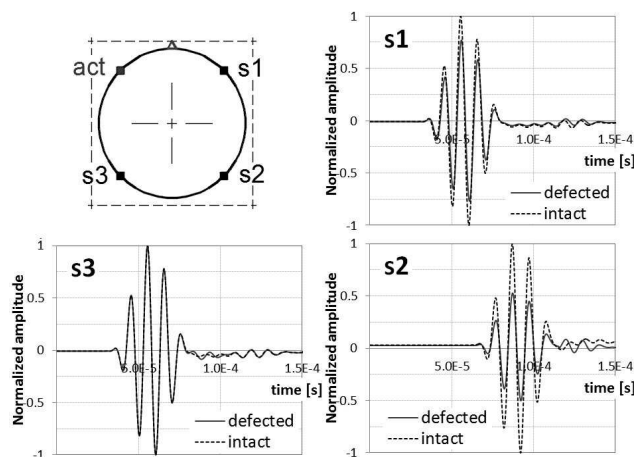

Fig. 6. Comparison of wave propagation for second configuration of sensor location

Rys. 6. Porównanie propagacji fali sprężystej dla drugiej konfiguracji rozmieszczenia sensorów

## CONCLUSIONS

The detection of fatigue damage initiation in a composite plate with a circular hole is crucial from the durability point of view. The guided wave propagation method, widely used in shell and plate structures can be also applied to local damage initiation detection. The sensitivity of the multipoint measuring system depends on the location of the sensors. Reasonable and accurate early detection of fatigue damage requires careful analysis and optimal design of the location and number of measuring points. The excitation and acquisition of the dynamic response of the structure directly on the hole edge allow one to detect small visible structural changes and can be analysed by a damage detection algorithm. The system configuration based on sensors placed at some distance from the analysed hole edge is insensitive to a small defect. Detailed analysis of the results demonstrates that the further studies are needed in order to verify the proposed system in a practical

application. The experimental verification of the numerical results will be presented in future research.

## Acknowledgments

The research project has been financed by the National Science Center Poland, pursuant to decision No. DEC-2013/09/B/ST8/00178.

## REFERENCES

- [1] Michaels J.E., Detection, localization and characterization of damage in plates with an in situ array of spatially distributed ultrasonic sensors, *Smart Mater. Struct.* 2008, 17, 035035.
- [2] Muc A., Stawiarski A., Location of delaminations in curved laminated panels, *Composite Structures* 2015, 133, 652-658.
- [3] Xu B., Yu L., Giurgiutiu V., Advanced methods for time-of-flight estimation with application to Lamb wave structural health monitoring, *Proc. Int. Workshop on SHM 2009*, 1202-1209.
- [4] Guo N., Cawley P., The interaction of Lamb waves with delaminations in composite laminates, *J. Acoust. Soc. Am.* 1993, 94, 2240-2246.
- [5] Ihn J-B., Chang F-K., Pitch-catch active sensing methods in Structural health monitoring for aircraft structures, *Struc. Health Monit.* 2008, 7(5), 5-19.
- [6] Liu X., Zhou C., Jiang Z., Damage localization in plate-like structure using built-in PZT sensor network, *Smart Structures and Systems* 2012, 9(1), 21-33.
- [7] Ostachowicz W., Kudela P., Malinowski P., Wandowski T., Damage localisation in plate-like structures based on PZT sensors, *Mechanical Systems and Signal Processing* 2009, 23(6), 1805-1829.
- [8] Cho H., Lissenden C.J., Structural health monitoring of fatigue crack growth in plate structures with ultrasonic guided waves, *Structural Health Monitoring* 2012, 11, 393-404.
- [9] Papazian J.M., Nardiello J., Silberstein R.P., Welsh D., Grundy D., Carven C., et al., Sensors for monitoring early stage fatigue cracking, *Int. J. Fatigue* 2007, 29, 1668-1680.
- [10] Kostson E., Fromme P., Fatigue crack growth monitoring in multi-layered structures using guided ultrasonic waves, *Journal of Physics: Conference Series* 2009, 195(1), 012003.
- [11] Chang Z., Mal A., Scattering of Lamb waves from a rivet hole with edge cracks, *Mechanics of Materials* 1999, 31, 197-204.
- [12] McKeon J.C.P., Hinders M.K., Lamb wave scattering from a through hole, *Journal of Sound and Vibration* 1999, 224, 843-862.
- [13] Masserey B., Fromme P., In-situ monitoring of fatigue crack growth using high frequency guided waves, *NDT & E International* 2015, 71, 1-7.
- [14] Cobb A.C., Michaels J.E., Michaels T.E., An automated time-frequency approach for ultrasonic monitoring of fastener hole cracks, *NDT & E International* 2007, 40, 525-536.
- [15] Stawiarski A., Barski M., Pająk P., Fatigue crack identification by dynamic analysis of elastic wave propagation, *Dynamical Systems - Mathematical and Numerical Approaches* 2015, 489-500.
- [16] Muc A., Stawiarski A., Wave propagation in composite multilayered structures with delaminations, *Mechanics of Composite Materials* 2012, 48(1), 101-106.
- [17] Muc A., Stawiarski A., Location of delaminations in curved laminated panels, *Composite Structures* 2015, 133, 652-658.

- [18] Muc A., Stawiarski A., Identification of damages in composite multilayered cylindrical panels with delaminations. *Compos. Struct.* 2012, 94 1871-1879.
- [19] Giurgiutiu V., *Structural Health Monitoring of Aerospace Composites*, Elsevier Inc. 2016.
- [20] Larrosa C., Lonkar K., Chang F-K., In-situ damage classification for composite laminates using Gaussian discriminant analysis, *Structural Health Monitoring* 2014, 13(2), 190-204.
- [21] Taylor S.G., Park G., Farinholt K., Todd M.D., Fatigue crack detection performance comparison in a composite wind turbine rotor blade, *Structural Health Monitoring* 2013, 12(3), 252-262.